

**IP65**  
WATERPROOF

**SHOCK**  
PROOF

**DIGITAL 3D TESTER**

**INSIZE PLUS**  
MADE IN EUROPE

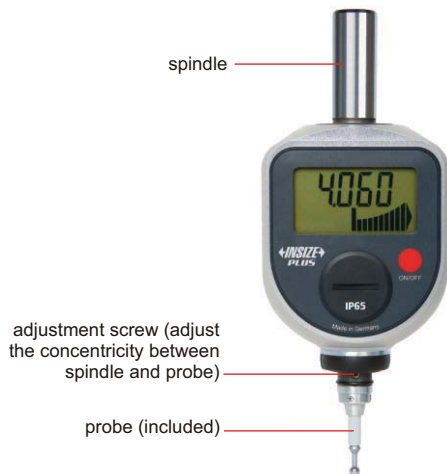

**2846-3D**

if the probe is pressed too much, the probe breaks at the breaking point, in order to prevent damage of the main body

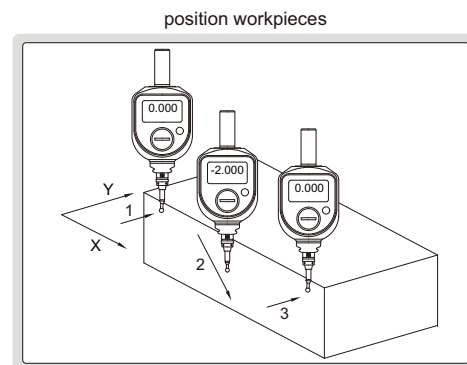
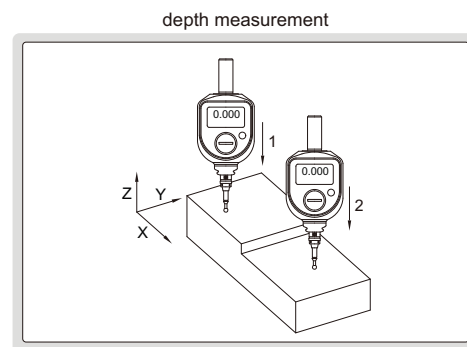
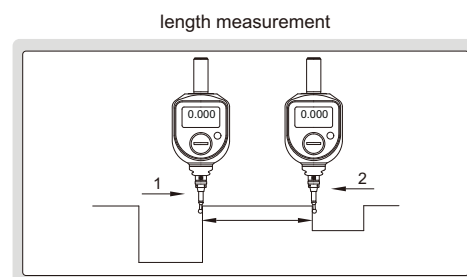
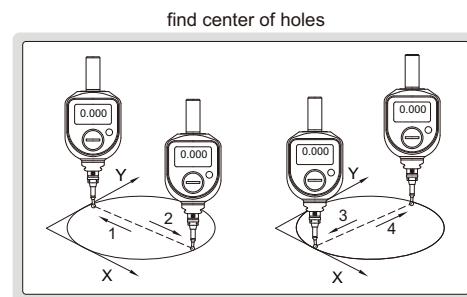
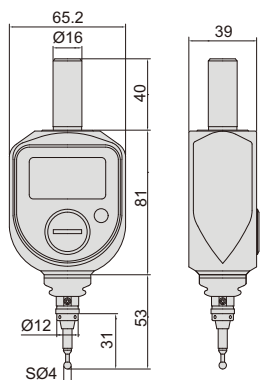
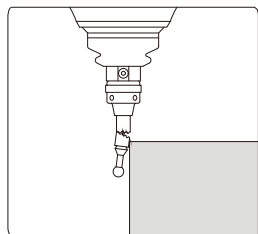

- Shockproof, IP65 dust/waterproof
- Mainly used for milling machines and CNC machine tools
  1. determine coordinate point on workpieces
  2. find center of holes
  3. adjust and position workpieces
- Can be used to measure length and depth
- Reading shows movement value of probe.  
for example, if probe moves 0.01mm, reading changes 0.01mm
- Large working range on three axes (X, Y, Z),  
which avoids damage of probes due to collision by mistake
- Optional accessory: probe (code **2840-N1**)

Code	Range	Resolution	Repeatability at zero (one direction)	X, Y, Z range
<b>2846-3D</b>	±2mm	0.005mm	±0.005mm	6mm